



SUPERFLAT™
TV Swivel 52" / 65"

Operating Manual





⇒	K.01	INTRODUCTION		
⇒	K.02	FEATURES		
⇒	K.03	PRODUCT DIMENSIONS		
⇒	K.04	INITIAL PRODUCT SET-UP		
			Set-up	P.06
			Images	P.07 - P.09
⇒	K.05	PRODUCT CONTROL		
			Room control system	P.10
⇒	K.06	PRODUCT INTEGRATION		
			Information TV swiveling	P.11
⇒	K.08	TROUBLE SHOOTING		
⇒	K.09	LEGAL NOTICE		

Intended Use

The product swivels out of LCD and plasma TV equipment.

All company names and product names are trademarks of the corresponding owner. All rights reserved. The scope of supply can vary depending on the product and the range of fixtures and fittings. Please check that the product supplied is complete and inform us within seven days of delivery if the scope of supply is not complete.

Safety and Hazards Recommendations

Please read this chapter carefully and follow all of the instructions provided. In this way you are able to guarantee the reliable operation and a long lifespan for your lift system. Keep the operating manual in a safe place.

In the event of damage which is the result of non compliance with this operating manual, all claims pertaining to the guarantee are null and void. We generally accept no responsibility for secondary damage.

We accept no responsibility for damage to objects or persons which is caused by the inappropriate use of the product or through ignoring the safety instructions. In such cases, all claims pertaining to the guarantee are null and void.

- ⇒ For safety reasons, the unauthorized conversion and/or changing of the product is not permitted. Do not dismantle this product.
- ⇒ This product is not a toy and does not belong in the hands of children.
- ⇒ Do not allow the product to become damp or wet.
- ⇒ Do not leave the packaging material lying around as children may choke if they swallow it.
- ⇒ The product will be damaged if it is dropped, even from a low height.
- ⇒ Before using the product for the first time, please check that the free raising and lowering of the Flatlift including the mounted TV equipment is possible and ensure a collision-free run.

For legal reasons and insurance purposes, your Flatlift is equipped with an 'automatic safety device'.

This means that the button which controls the raising and lowering must be pressed down all the time.

The system stops and remains in the same position as soon as you let go of the button.

Quality

In the choice of our components, our primary focus was on ensuring a high level of functionality, straightforward use, safety and reliability.

We would like to thank you for the trust you have placed in our Flatlift brand products.

We can help you with your installation through providing individual customer care.



Outperform. Outlast.™

BUY NOW

Features:

- ⇒ Installation dimensions Flatlift
H=29.52" W=60.63" D=2.36"
- ⇒ TV weight max. 330 lbs
- ⇒ TV size 52-65" (inch)
- ⇒ opening rate 18%/h
- ⇒ Soft Start / Soft Stop
- ⇒ Low noise level < 45 db
- ⇒ Environmental temperature from +5°C bis 40°C

Scope of supply:

- ⇒ Flatlift Superflat
- ⇒ Control box
- ⇒ 110V power supply unit
- ⇒ Motor cabel (1x)
- ⇒ IR remote control
- ⇒ Touchpanel

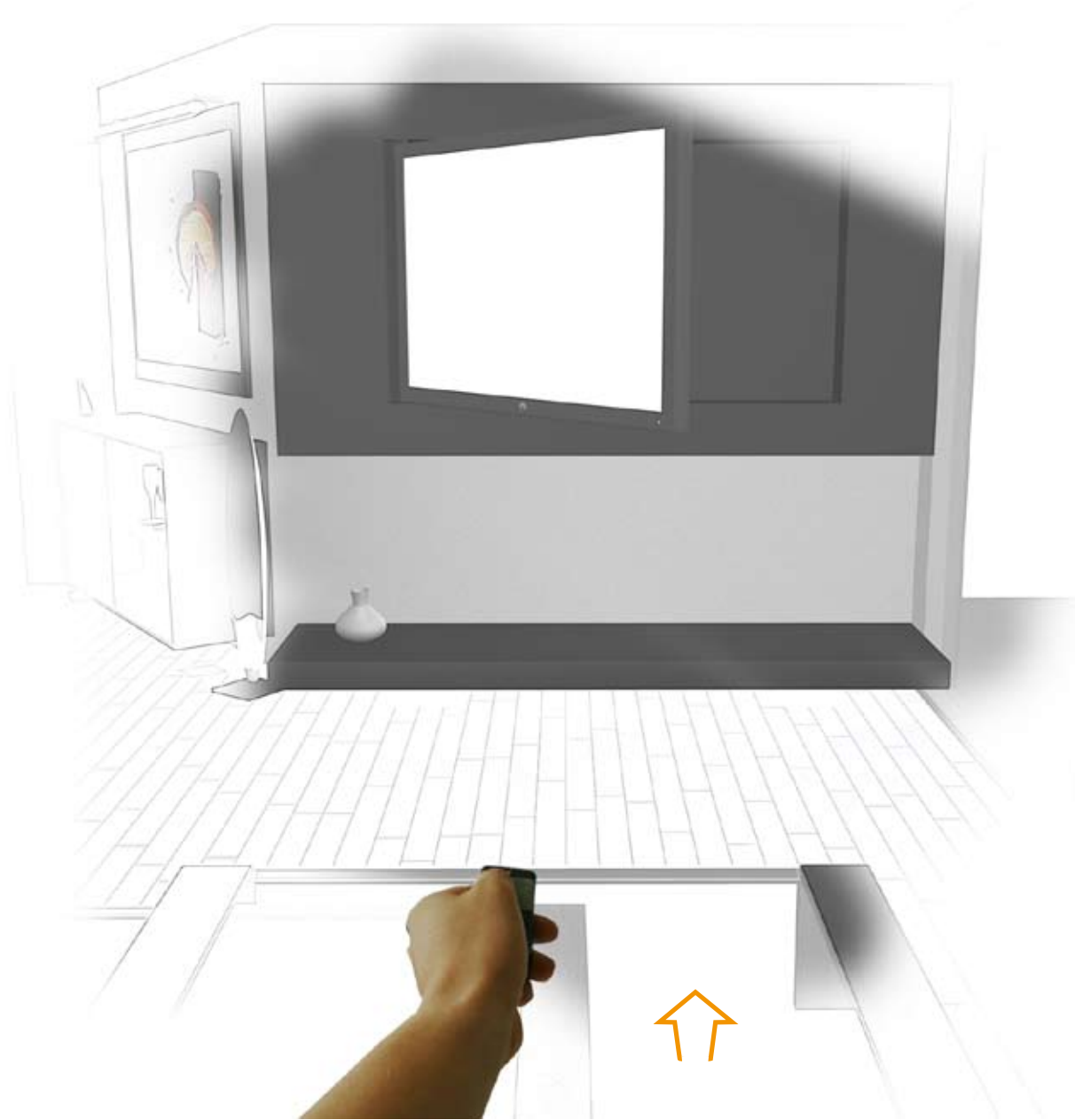

Outperform. Outlast.[™]

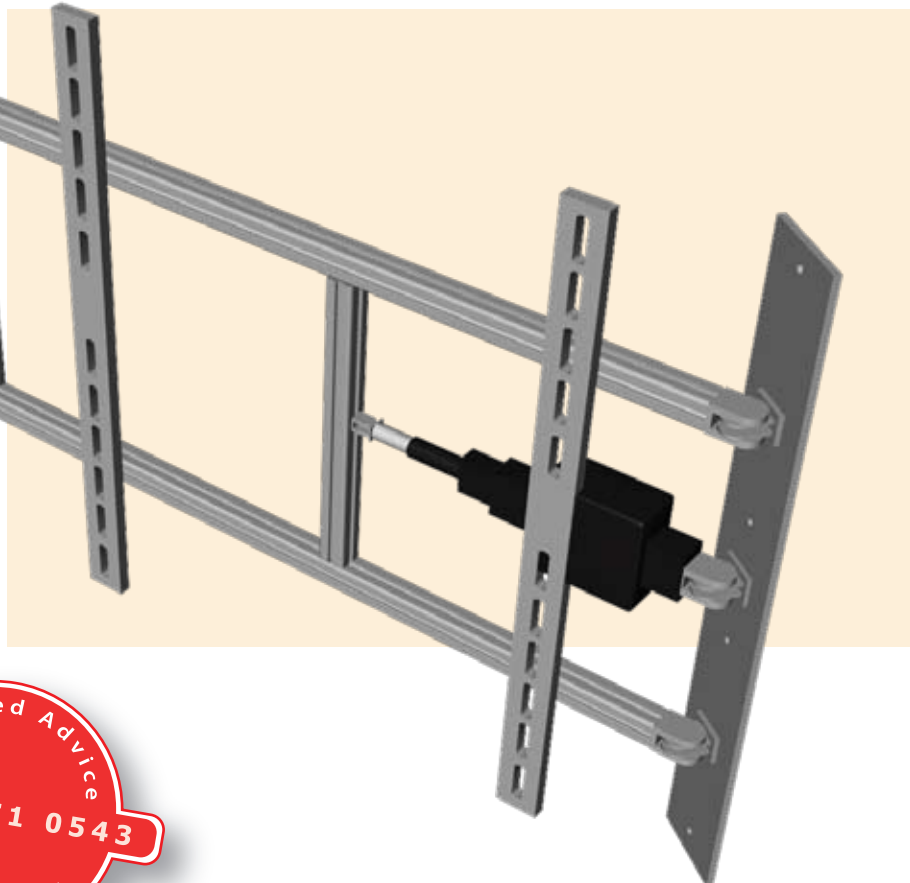
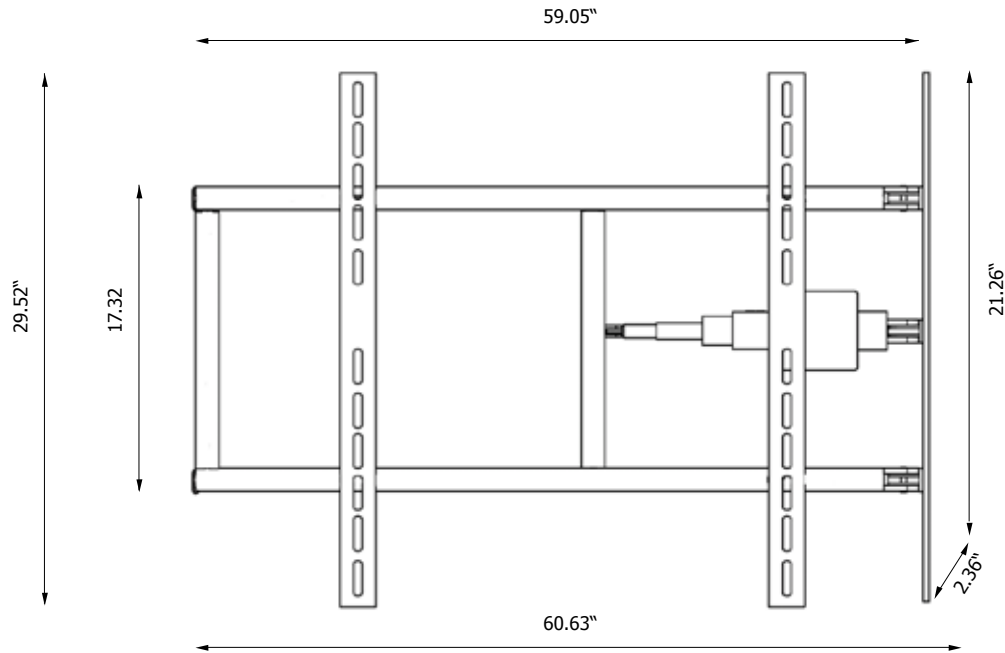

Initial setting / installation:

- 1) Fix your Flatlift Superflat (img.1, no.1 and P.07, img. 1b) with 2 screws upon the wall. Depending on assembly you can swivel your Superflat system left- or rightwards.
- 2) Connect the motor (img.1, no. 2) with the motor cable (P.08, img. 3) through the control box (P.08, img 2, no. 3).
- 3) Connect the RJ-45 Western plug of the touchpanel (P.09, image 6, no. 7) to the control box (P.08, img. 2, no. 5).
- 4) Link the power cord (P.08, img. 5) with the control box (P.08, img. 2, no. 6) and than with the mains voltage.
- 5) Connect the IR eye (P.09, image 5, no. 8) with the touchpanel. Be sure, that the IR eye (p.07, image 5, no. 9) is not hidden. Place the IR receiver well visibly, because it is very important for the connection between your IR remote control and IR eye.
- 6) Swivel out and in your Superflat for 2 times. Observe at the moving that your system has a collision clear course.
- 7) You can scroll the vertical mountings to adept them to your TV holdings (P.07, img. 1c).
- 8) Now you can mount your TV (P.07, img. 1d) on the Superflat. Please consider that the liftsystem needs space between the TV and the e.g. covering (P.11, img.1).
- 9) And that´s it. Now you can use your IR remote control comfortable with the buttons „left“ and „right“ (P.09, image 10, no. 10 and no. 11) to control your Flatlift system.

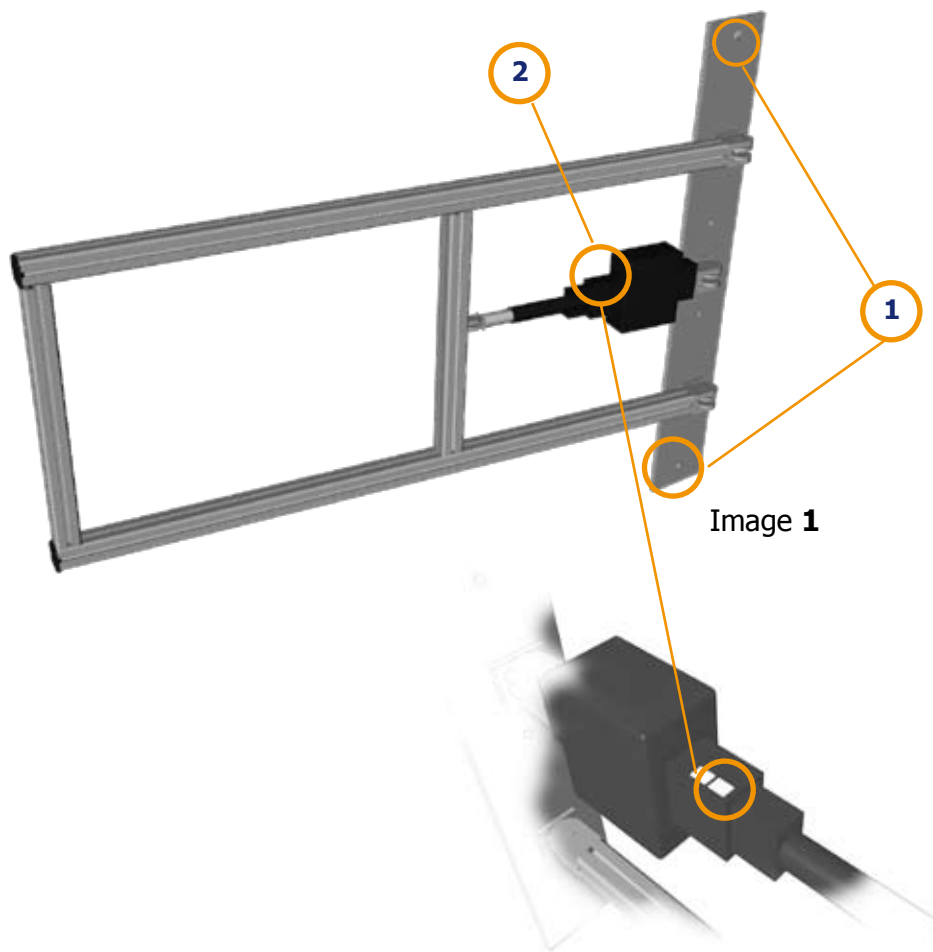

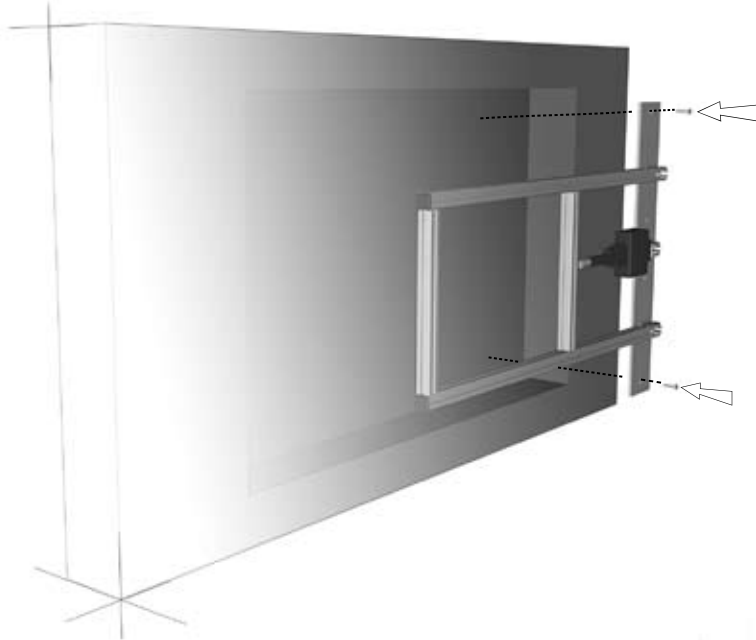

Image 1b

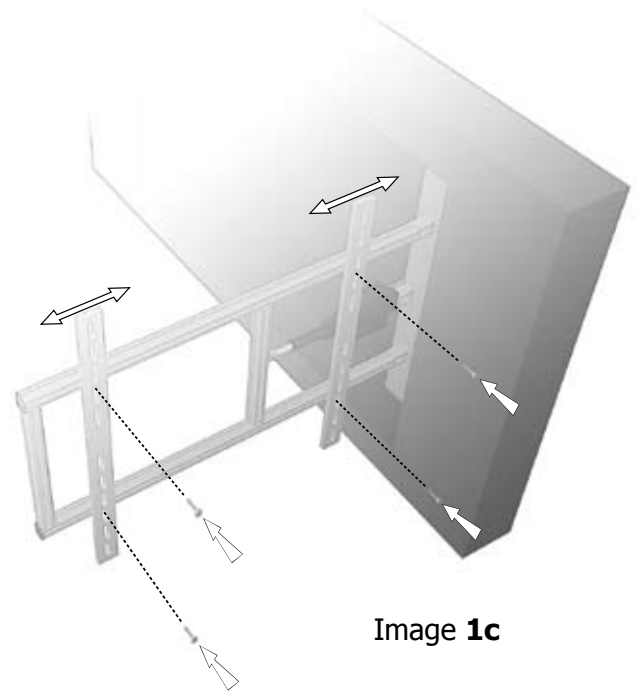

Image 1c

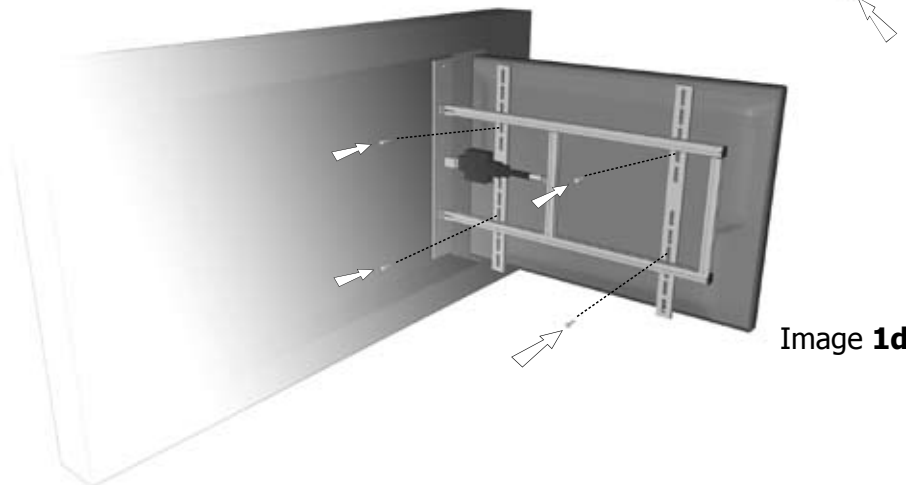

Image 1d



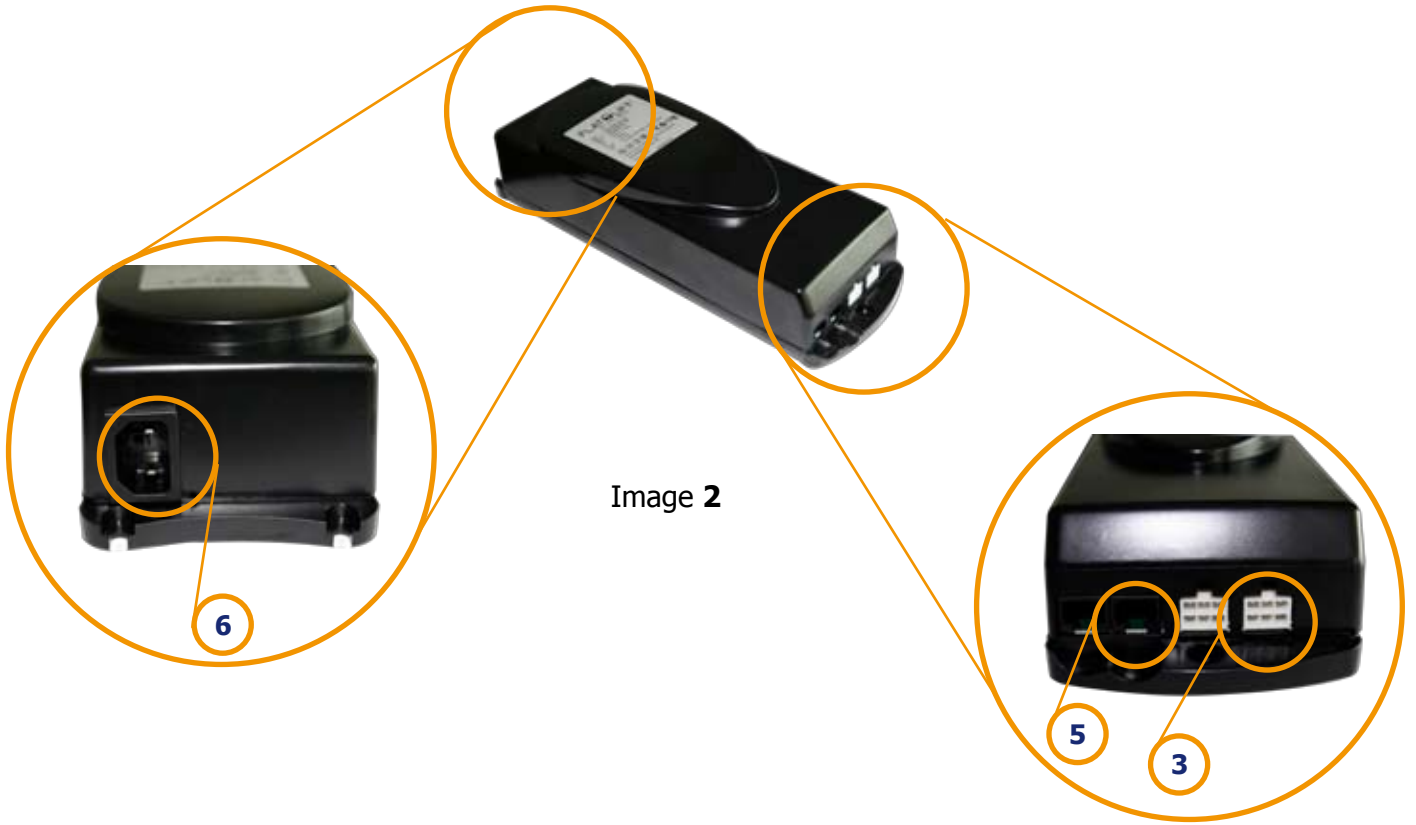

Image 3



Image 4



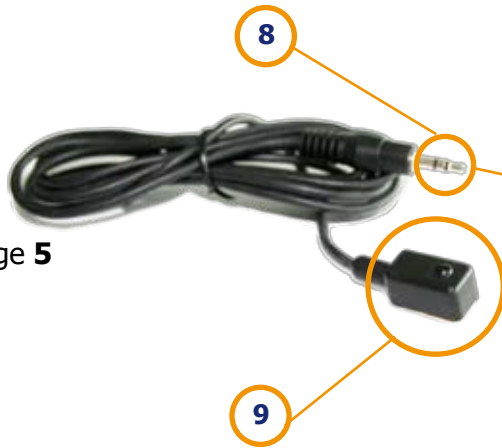

image 5



Image 6

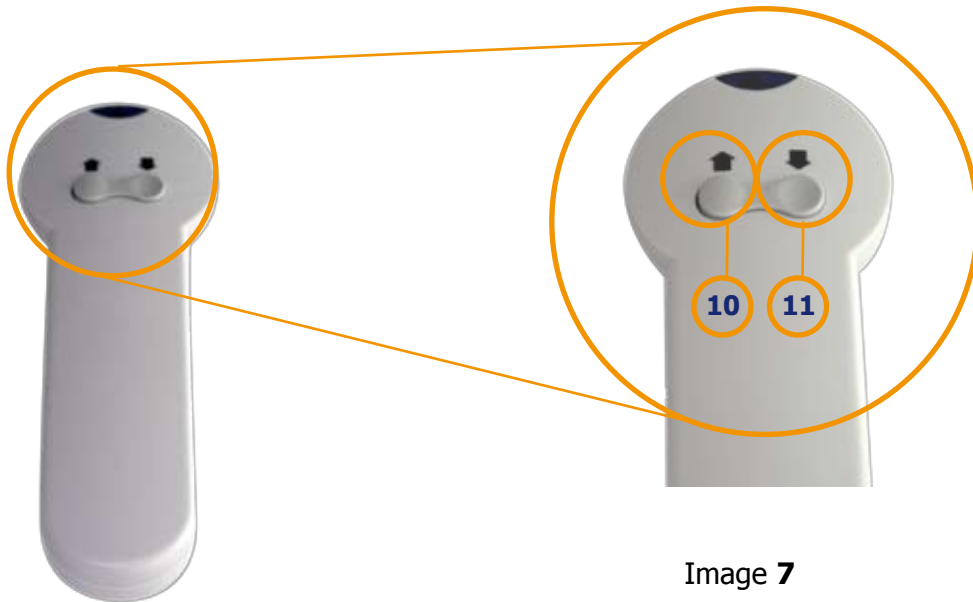

Image 7





Image 1

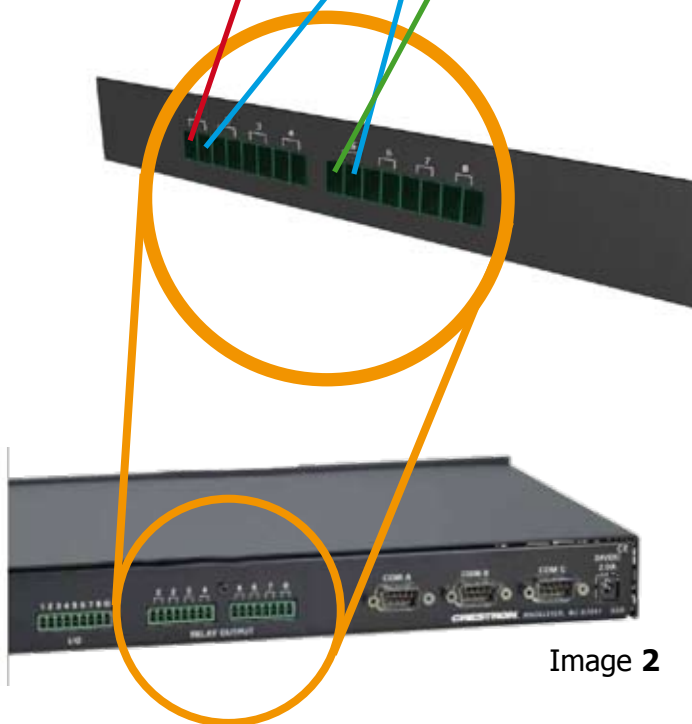

Image 2

Connection to a room control system:

You can connect your Flatlift to a room control system (image 6) if this system has 2 relay outputs with potential free contacts. These relays must be actuated for a programmable time period.

- 1) Use the cables (red, blue and green) from the image 1.
- 2) Now connect the blue and red cable to one of the relay outputs (control command: lower Flatlift).
- 3) Bridge the blue cable onto the second relay output and also attach the green cable to this relay output (lift Flatlift).



Outperform. Outlast.[™]

Information TV swiveling:

The Superflat can swivel out up to 90° (img.1)

Please consider that the liftsystem needs space between the TV and the e.g. covering.

The space appropriate the TV depth (img 1, no. 1).
It is very important to consider this to prevent a collision and to prevent your TV and Superflat liftsystem of an damage.

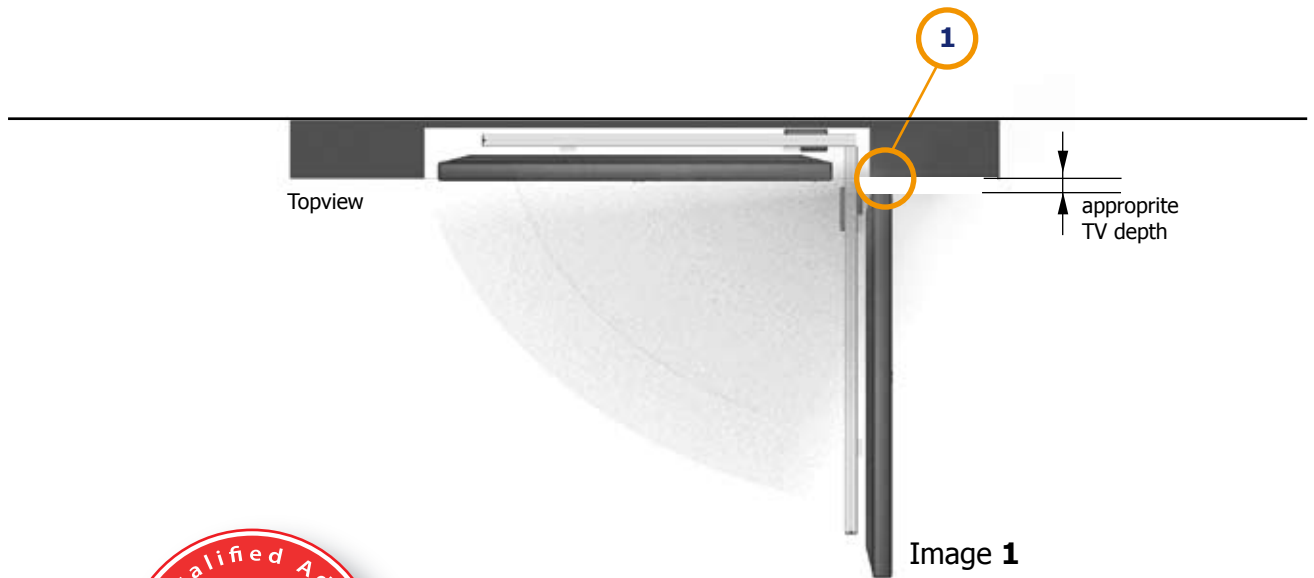

Outperform. Outlast.™

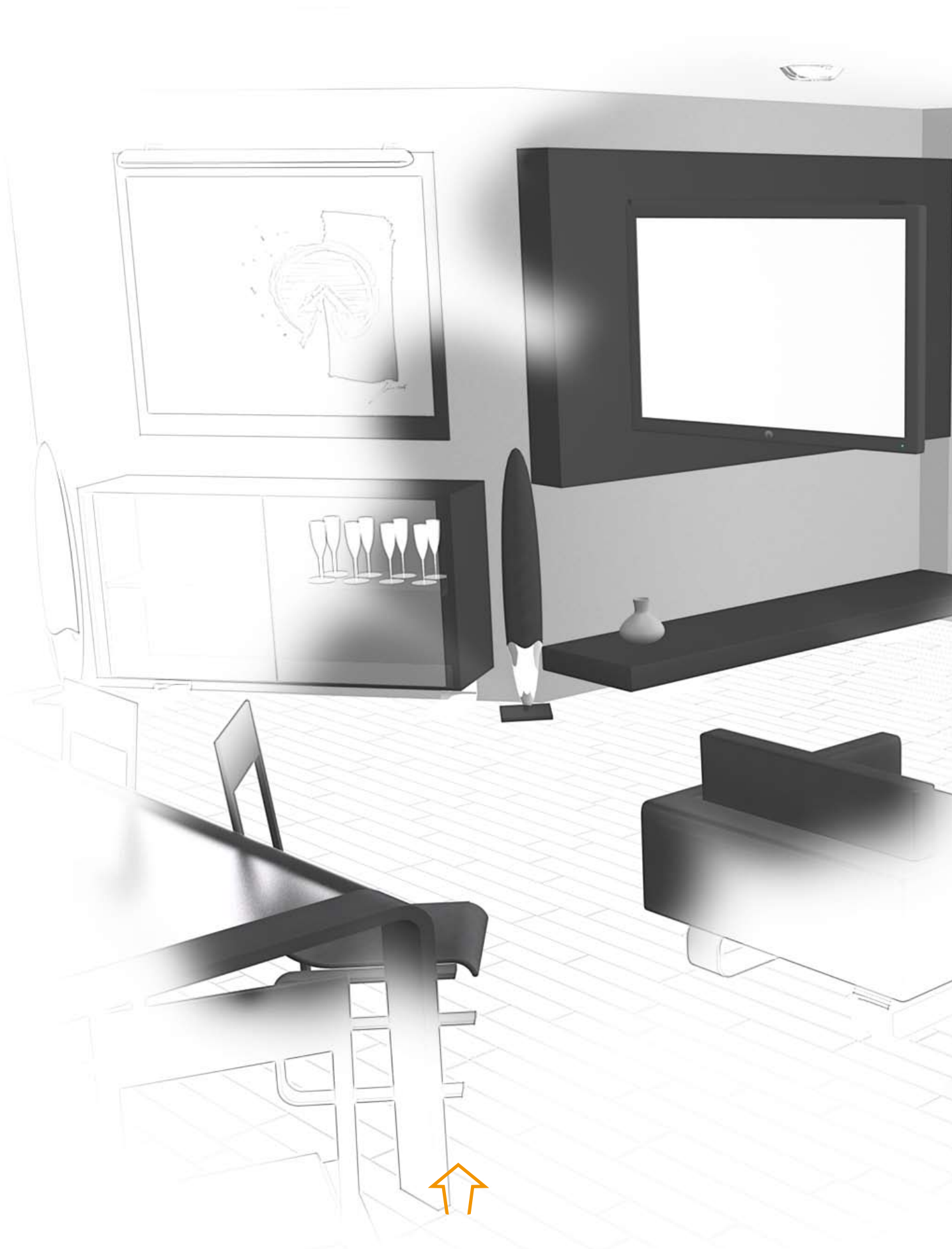

Outperform. Outlast.™



The Flatlift Superflat automatic swivel LCD-/Plasma Wallmounts are special developed motorized mounting concepts for LCD and Plasma Flatscreens. This system fits for TV sizes from 30" to 65".

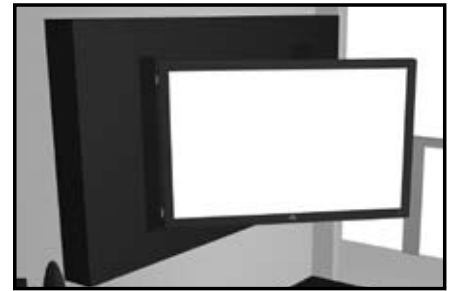
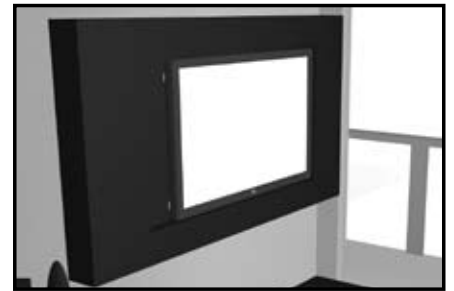

Trouble shooting:

If your Flatlift is not working properly, please make sure you check the following things:

The Flatlift won't move up or down

- ⇒ Is the power cord attached to the control box?
 - S Check the mains connection
- ⇒ Are all of the plugs properly connected to the control box? (NOTE: plugs which are not connected properly can damage the system)
 - S Check all of the connections
 - S The motor cables must be connected starting at port 1 and going up
- ⇒ Is there any evidence of damage to the cables, the control box, the remote control or the Flatlift?
 - S Damaged components must be exchanged. Please contact us.
- ⇒ The Flatlift has stopped and will only move in the wrong direction.
 - S Is your Flatlift fully extended already?
 - S Is the TV too heavy?
 - S Remote control command possibly deleted!
 - S Programming or initialisation error!
 - S Stopping point incorrectly programmed
- ⇒ Have you, in error, attached a TV to your Flatlift which is too heavy?
 - S Take the TV off the Flatlift and now see if the Flatlift works.
- ⇒ Is the remote control working?
 - S Change the battery in the remote control if necessary.
- ⇒ Is the receiver receiving the signals?
 - S When activating the remote control, the relay should 'click' on both channels. (If the receiver does not 'click', please delete the channels and reset them.)
- ⇒ The lifting mechanism jerks or stutters?
 - S Please check as to whether another frequency source is also transmitting at 433 Mhz in your house (possible sources of problems: garage door opener, baby phone, alarm system or intercom). With a frequency jammer you will have to change over to a frequency of 868 Mhz! A free changeover from 433 Mhz to 868 Mhz is only possible within the first 7 days subsequent to the date of delivery.

Please contact us if this particular point is relevant to you.

If you experience any problems setting your system up or you experience an error, you can also contact us over the telephone or via Email:

Customer Service:

Via email: info@flatlift.de

Our telephone service time is 7.30 am - 5.30 pm. The telephone number is +49 (0) 62 41 - 97 20 10. Please have the following information at hand / or include it in any email that you sent to us:

- ⇒ Your customer number
- ⇒ Your invoice number or delivery receipt number
- ⇒ The purchase date of your Flatlift
- ⇒ The name/model of your Flatlift system



FLATLIFT Referenzen



Legal Notice

FLATLIFT TV Lift Systeme GmbH
 Gewerbegebiet Südwest
 Nievesheimer Str. 15
 67547 Worms, GERMANY
 Tel.: +49 (0) 62 41 97 20 10
 Fax.: +49 (0) 62 41 97 20 12
 info@flatlift.de
 www.flatlift.de
 Hours of business: Mon-Fri. 7:30 am- 5:30 pm
 Managing Director: Sascha Rissel
 HRA Mainz: HRB 40436
 USt. (VAT) ID: On request
 Status of document: JULY 2008

